



ROSTEC WDIS8 Word Distribution Amplifier for GPU frame

General description

The WDIS8 is a Word Distribution amplifier with eight individually buffered outputs. It is intended as an extension to the various Reference Generators installed in the GPU frame, but it is also able to distribute a word signal, not generated in the GPU frame environment, via an external input on the back panel sub-d connector.

Further, the WDIS8 is able to decode signals on the GPU bus into a variety of clock signals, used to synchronize a range of popular PC based signal processors, Hard Disc recording systems and DVD mastering equipment

Outputs

There are eight Word outputs available on the sub-d connector on the back panel of the GPU frame. All outputs are individually buffered and single ended. Output impedance is 75 Ohms.

GPU bus input

GPU input is the normal mode. A jumper on the PCB selects GPU input or external input.

External input

The external input is unbalanced and TTL compatible. Pulse shaping is performed by means of an input Schmitt Trigger with 0,3V hysteresis.

Note that when the external input mode is selected, output CH 8 on the back panel connector is changed to input.

Thus only seven outputs are available when this mode is selected.

Output frequency selection

When the WDIS8 is in GPU mode, each output can be configured individually by setting the internal jumpers.

The available frequencies are:

1xFs (sampling frequency)

2xFs

4xFs

8xFs

16xFs

32xFs

64xFs

128xFs

256xFs

Fs received from the DSG3 or the DSG5E Reference Generator can be 44.1 kHz, 48 kHz or 96 kHz.

This enables the WDIS8 to generate a wealth of clock frequencies, ranging from 44.1 kHz to 24.576 MHz

Block Schematic

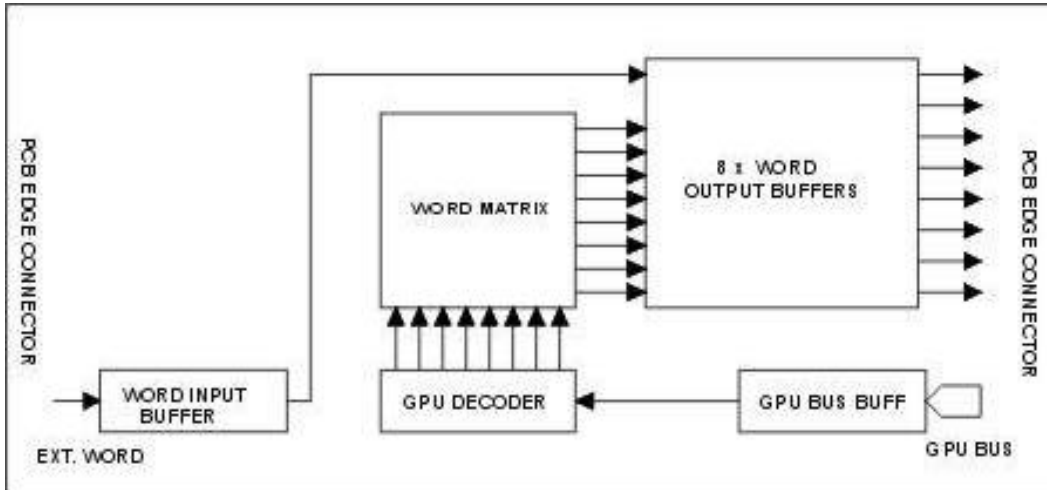

Input output connections

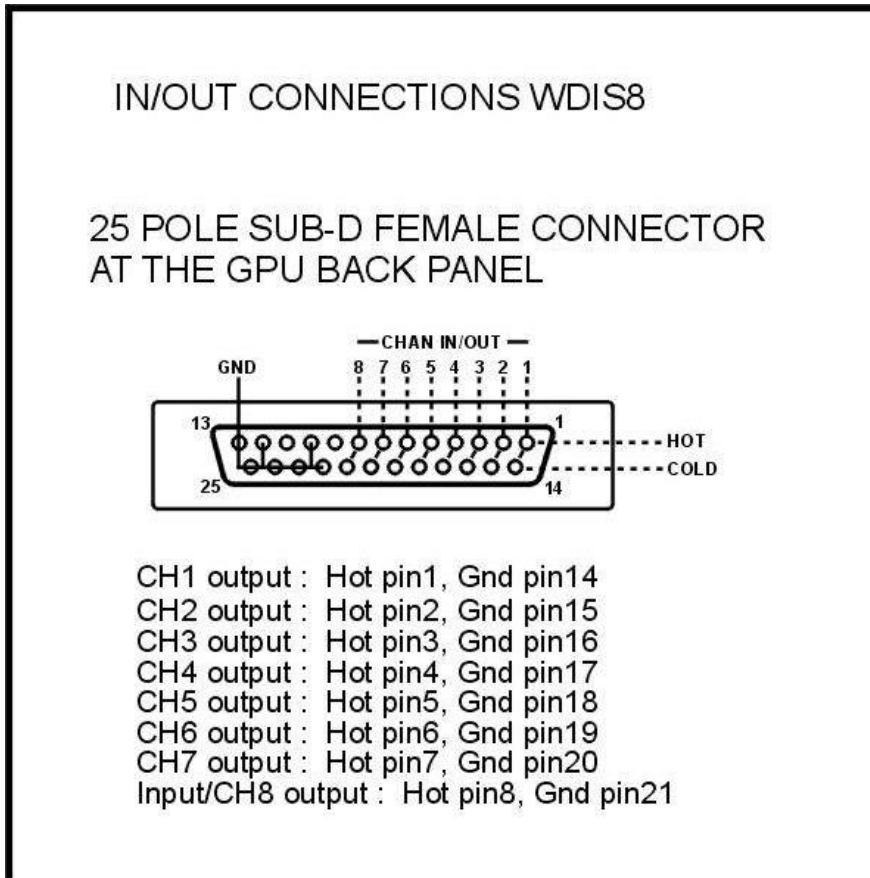

Electrical specifications:

Inputs	: GPU Bus signals : Word 10 kohms, unbalanced. TTL level
Outputs	: 8 x word 75 ohms, TTL level, single ended (GPU mode) : 7 x word 75 ohms, TTL level, single ended (ext. input mode)
Frequency range	: 10 kHz to 27 MHz

Jumper settings

On the matrix, the output frequency for each channel can be individually selected. There are 10 possible settings:

Seen from edge connector to front:

1	Input
2	256 x Fs
3	128 x Fs
4	64 x Fs
5	32 x Fs
6	16 x Fs
7	8 x Fs
8	4 x Fs
9	2 x Fs
10	1 x Fs

Fs is the Sampling Frequency selected on the front panel of the Reference Generator.

Choice no.1 (Input) is only available when the input/output jumper is set to Input. In this position, CH8 is an input and CH1 - CH7 are outputs.

Choices no. 2 – 10 are only available when the GPU Select Jumper is set to ON. This setting enables the GPU signals and activates the decoding matrix.

Running the ADIS8 with both external input and GPU signals at the same time is possible, but it should be considered carefully.

If the signals are not in sync, this may create a wandering ringing on the edges of the clock signals, causing interference and glitches in the connected equipment.

Jumpers on the PCB

