

Technical data sheet

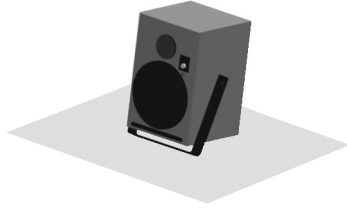

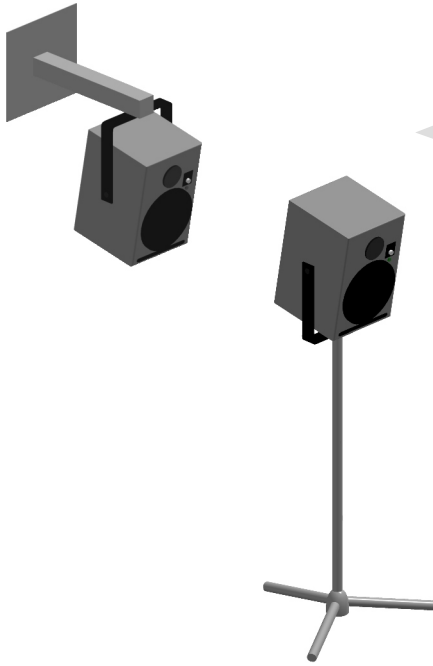

*C.P.R.: Compensated Phase Response system.
*A.O.I.: Adaptive Output Impedance system.

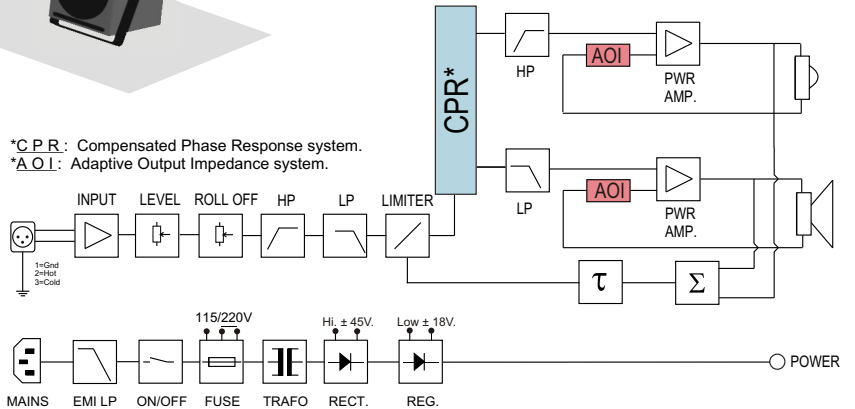

- Puissance RMS **70+30 W**
- Power RMS
- Puissance programme **100 W**
- Program power
- Impédance d'entrée **Sym, 10k Ohms**
- Input Impedance
- Sensibilité pour 100 dB @ 1m **0.775 V**
- Sensitivity for 100 dB @ 1m
- Rapport signal sur Bruit **-96 dBA**
- Signal to Noise Ratio
- Saturation d'entrée **24 Vpp**
- Input Overload
- Niveau max. continu, 1m **101 dB (single)**
- Continuous Max SPL, 1m
- Niveau max. programme, 1m **112 dB (pair)**
- Program Max SPL, 1m
- Réponse à -6 dB **58 - 22000 Hz**
- Response at -6dB
- Tolérances **±2.5 dB (68Hz - 18kHz)**
- Tolerances
- Distorsions THD **< 1.8% (75Hz-15kHz)**
- Distortion THD
- Phase tolérances **±45° (260Hz - 16kHz)**
- Phase tolerances
- Dispersion (B.R. 4 - 16 kHz) à -6 dB **100° x 100° (H x V)**
- Dispersion (P.N. 4 - 16 kHz) at -6 dB
- Système **2 Way(s)**
- System
- Fréquence de coupure **3.5 kHz**
- Crossover frequency
- Dim. basses Ext. / Membrane **Ø 144 mm / Ø 102 mm**
- Woofers dim. Ext. / Diaphragm
- Dim. aigues Ext. / Membrane **Ø 70 mm / Ø 20 mm**
- Tweeter's dim. Ext. / Diaphragm
- Connecteurs **1 x XLR F / 3P**
- Connectors
- Signal entrée **1=GND, 2=(+), 3=(-)**
- Signal input
- Matériaux du boîtier **MDF**
- Box Material
- Dimensions boîtier L x H x P mm **162 x 242 x 170**
- Dimensions cabinet W x H x D mm
- Poids net **5 Kg**
- Net Weight
- Tension de secteur **115/230V (50-60Hz)**
- Voltage
- Consommation **7 - 70 VA**
- Power Consumption
- Humidité Moy / Max **< 75% / < 90%**
- Mean / Max Humidity
- Température externe **5 - 40 °C**
- External Temperature

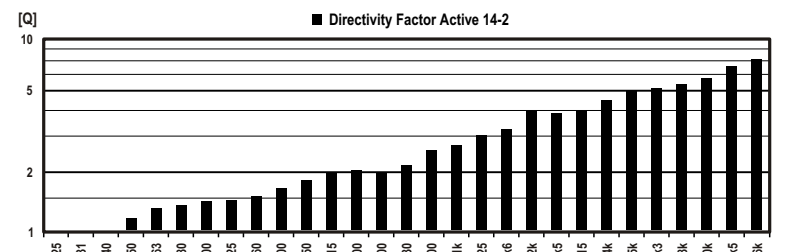
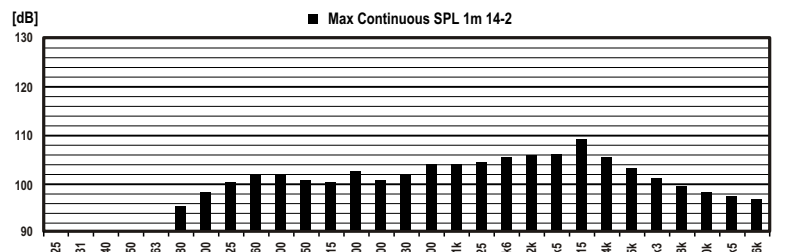
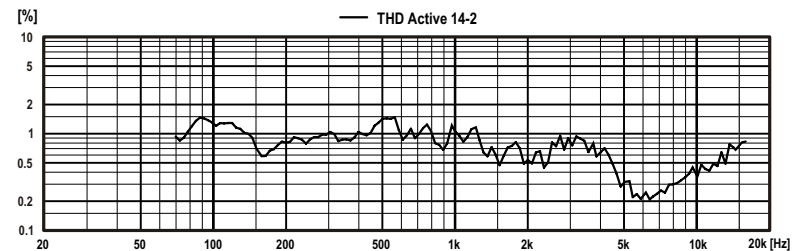
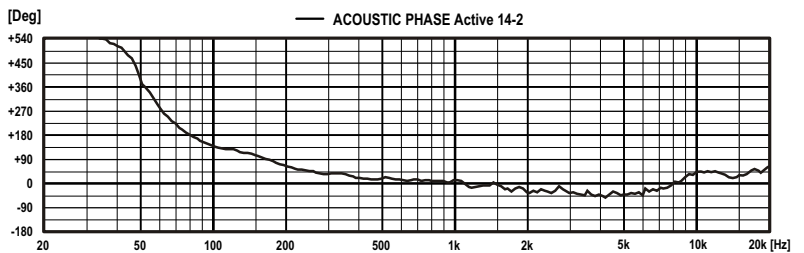
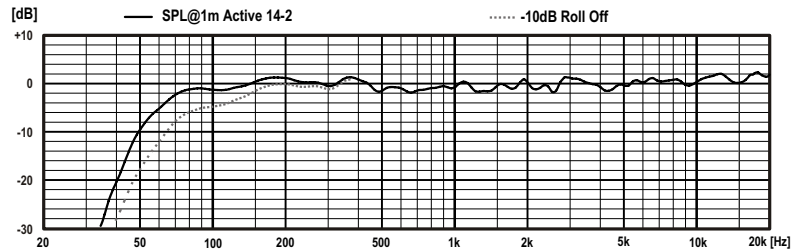

System setup

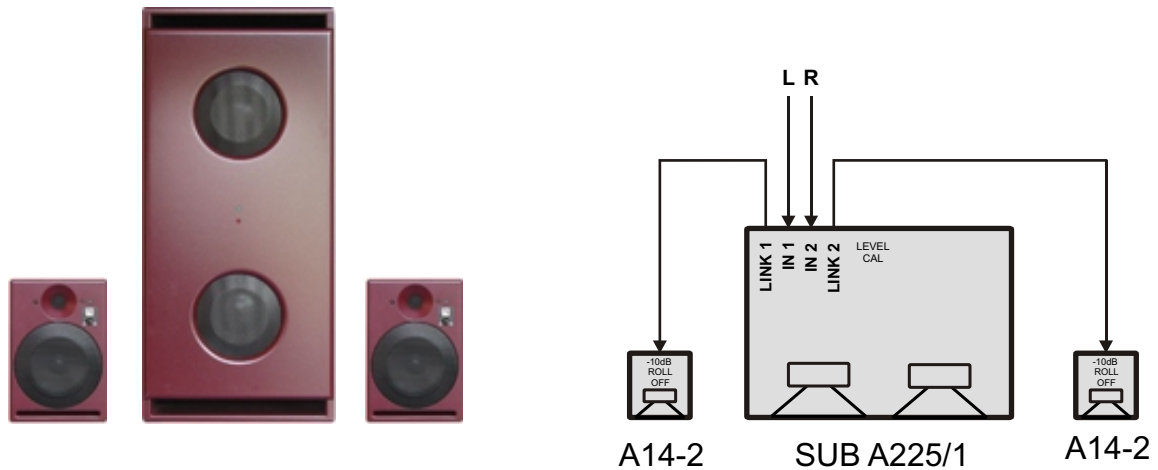

System Response

Impédance d'entrée **Sym, 5k Ohms**
 Input Impedance
 Saturation d'entrée **24 Vpp**
 Input Overload
 Sensibilité pour 100 dB @ 1m **0.775 V**
 Sensivity for 100 dB @ 1m
 Rapport signal sur Bruit **-96 dBA**
 Signal to Noise Ratio
 Niveau max. continu, 1m **108 dB**
 Continuous Max SPL, 1m
 Niveau max. programme, 1m **114 dB**
 Program Max SPL, 1m
 Réponse à -6 dB **28 - 22000 Hz**
 Response at -6dB
 Tolérances **±2.5 dB (30Hz - 18kHz)**
 Tolerances
 Distorsions THD **< 1.8% (30Hz-15kHz)**
 Distortion THD
 Fréquence de coupure **95Hz / 3.5 kHz**
 Crossover frequency

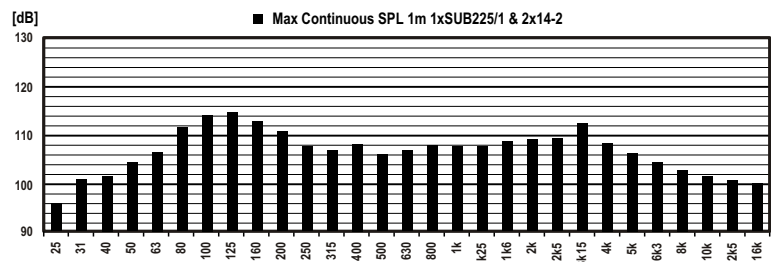
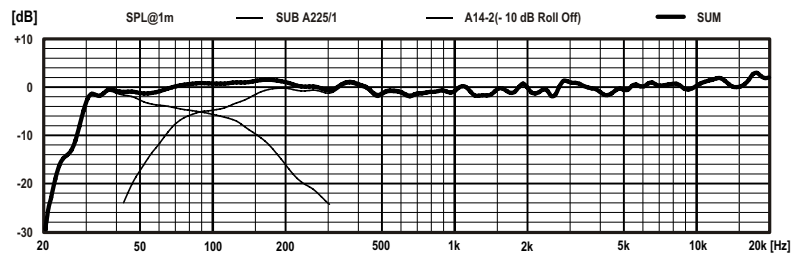

All dimensions are in mm

Mounting

1 x UNC 3/8"
like mic stand

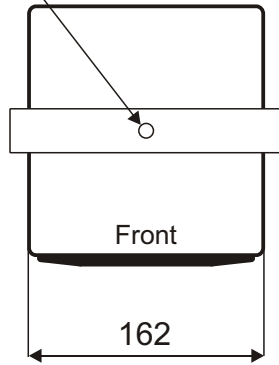

Bottom view

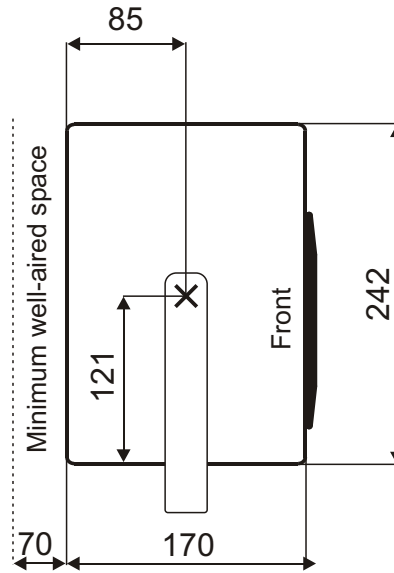

Side view

Acoustical axis

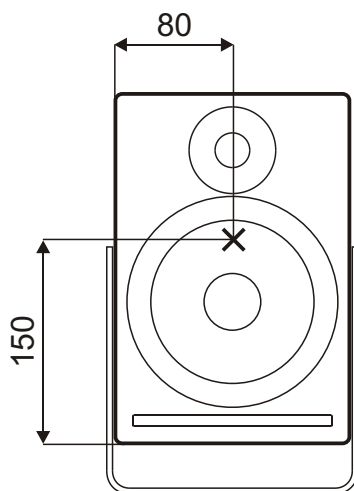

Front view